

CHEMICAL INJECTION PUMP

GAS DRIVEN

SINGLE HEAD

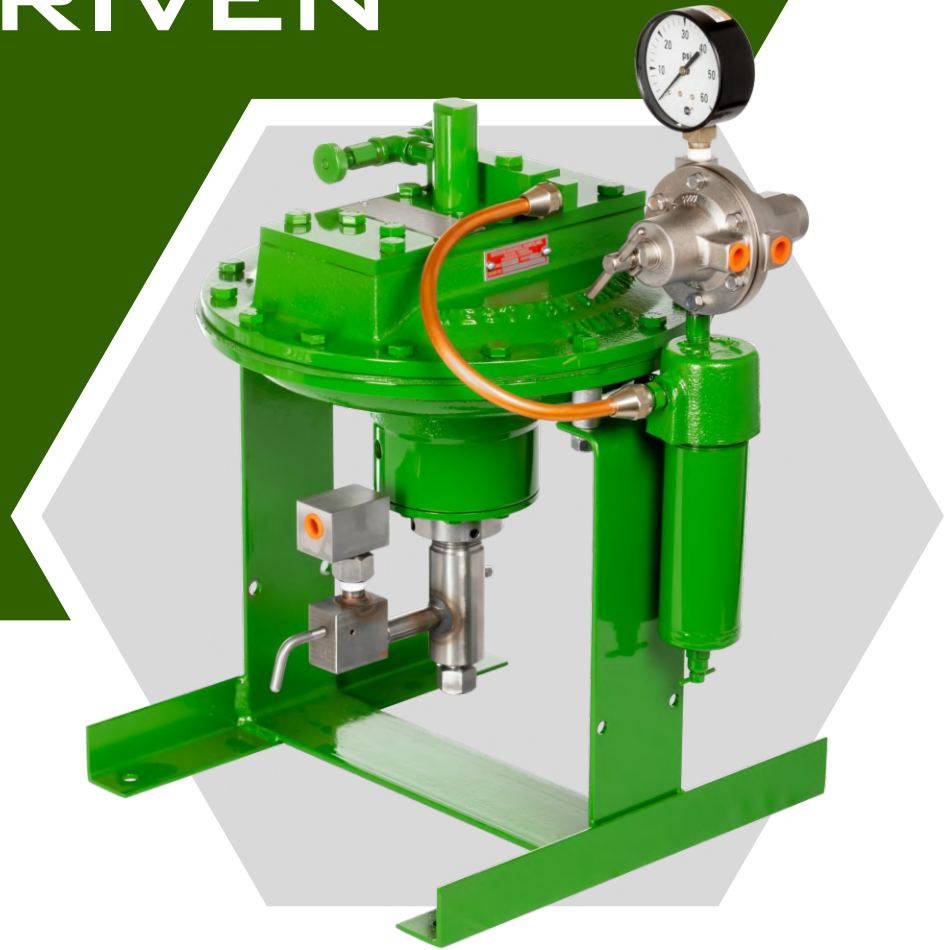

DFF

The model DFF chemical injection pumps are designed to be driven by pressurized gas. These positive displacement pumps have removable fluid ends with interchangeable inlet and discharge check valves. All moving components are enclosed requiring no lubrication providing low maintenance and excellent reliability.

The pumps are available in various materials and piston sizes to meet your specific chemical injection requirements. They can also be equipped with chemical tanks and an optional exhaust gas recovery (EGR) to capture exhaust gases.

For decades, Western Chemical Pumps model DFF pump has demonstrated reliable engineering and design, earning the trust of its users through rigorous testing and proven performance.

FEATURES

- ◆ Simple exhaust valve dial controlled chemical injection flow rate
- ◆ No lubrication required
- ◆ Exhaust gas recovery (EGR) option
- ◆ Sour gas trim option to improve corrosion resistance
- ◆ High pressure option up to 10,000 psi
- ◆ All models include inlet regulator and condensate drip pot
- ◆ Stainless steel piston and check valves come standard for longer life

WESTERN

TM



DFF PUMP CONFIGURATIONS

DFF	EG	3/8	#2	Y	PART NUMBER
↑	↑	↑	↑	↑	Model
DFF					Gas Driven Pump
					Exhaust Gas Recovery Kit
	EG				No EGR Kit
					EGR Kit
					Piston Diameter
		1/4			1/4"
		3/8			3/8"
		5/8			5/8"
		1			1"
		12-2			3/8" - High Pressure 10,000psi
					Attachments
			#1		Tank
			#2		No Tank
					Fluid End Material
					Steel (standard)
				Y	Stainless Steel
				Q	316 Stainless Steel

OPTIONS & UPGRADES

Exhaust Gas Recovery (EGR): Capture the motive gas as it is exhausted

Sour Gas Trim: Option that replaces brass components exposed to motive gas with stainless steel

High Pressure: Model 12-2 is a 3/8" piston that operates up to a maximum pressure of 10,000 psi

Material: Upgrade to Y or Q models for enhanced corrosion resistance

Piston Size: Multiple sizes available to fit your required injection flow rates and pressures

Resilient Seat Check Valves: Added O-ring provides better sealing capability, which is ideal for low viscosity fluids, such as methanol

Packing Seals: Buna-N, EPDM, Neoprene, PTFE (Teflon™), FKM (Viton™)

Prime Ball: Ceramic or tungsten

Tank: Optional 5 gallon stainless steel tank

Other unique or special order materials are available to fit your needs. Please inquire with your Western Chemical Pumps, Inc. distributor. Specify desired options when placing order.

PISTON DIA (IN)	MAX DISCHARGE PRESSURE (PSI)	FLOW RATE MIN - MAX (QTS / DAY)
1/4	5,000	0.2 - 51.4
3/8	5,000	0.5 - 115.6
3/8 (HP)	10,000	0.5 - 57.8
5/8	3,000	2.0 - 321.1
1	2,000	4.0 - 822.1

PISTON DIA (IN)	FLOW RATE (QTS / DAY)
1/4	= SPM x 1.07
3/8	= SPM x 2.41
5/8	= SPM x 6.69
1	= SPM x 17.13

SPM: Strokes per minute

DFF APPROXIMATE MOTIVE GAS CONSUMPTION
(SCF MOTIVE GAS CONSUMPTION PER 1 QT INJECTED CHEMICAL)

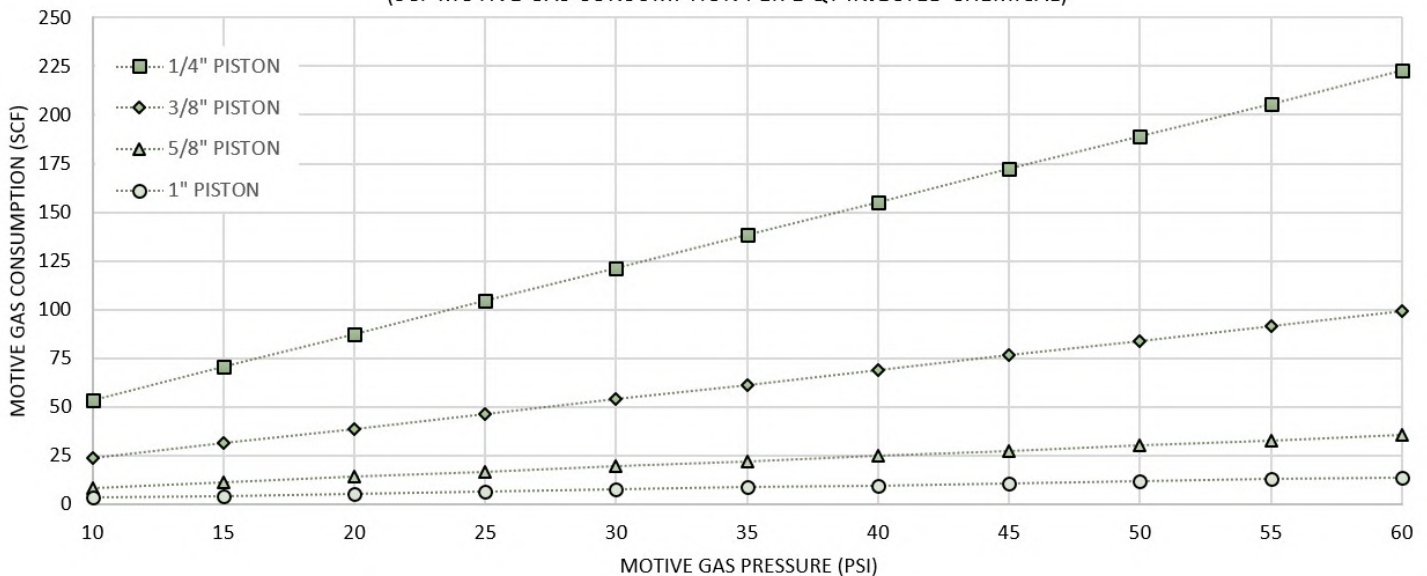

CAUTION

ENSURE CHECK VALVE FLOW IS IN THE DIRECTION OF THE ARROW. INCORRECT DIRECTION COULD CAUSE PUMP TO OVER PRESSURE.

PUMP IS NOT EQUIPPED WITH A DISCHARGE PRESSURE RELIEF VALVE. A PRESSURE RELIEF VALVE SHOULD BE INSTALLED AS CLOSE TO THE PUMP CHEMICAL DISCHARGE PORT AS POSSIBLE.

PUMP IS NOT EQUIPPED WITH AN INLET GAS PRESSURE RELIEF VALVE. IF INLET GAS PRESSURE EXCEEDS 70 PSI, A PRESSURE RELIEF VALVE SHOULD BE INSTALLED BETWEEN REGULATOR AND TOP PLATE INLET.

IF MOTIVE GAS IS FLAMMABLE, DO NOT OPERATE PUMP IN AN ENCLOSED AREA WITHOUT PROPER VENTILATION.

When the motive gas that is used to power a DFF pump is flammable, the exhaust gas will be flammable. If the pump is to be installed in an enclosure and powered with a hazardous gas, additional safety precautions must be taken.

The hazardous exhaust gas must be exhausted to a proper ventilation area and must never be allowed to accumulate in an enclosed area.

The vent hole on the bottom casting is required by design for the pump to function. However, in the event of a diaphragm failure, the hazardous gas will be exhausted thru this vent hole. It is necessary that this port be routed to a proper ventilation area.

When the drain valve on the bottom of the drip pot (D27) is opened for purging, hazardous gas will be released. It is necessary that this be exhausted to a proper ventilation area.

Any electrical wiring in the enclosure should be explosion proof and conform to the National Electrical Code. Perform a soap bubble test on all ventilation piping to ensure no leaks. Remove all possible sources of ignition and use extreme caution when entering the enclosure.

INSTALLATION & OPERATION

It is not necessary to bolt the pump to a base since there is little vibration during operation. The pump should rest on a level surface.

Connect inlet motive gas line. Regulator inlet pressure should not exceed 6,000 psi. Minimum pressure to power pump is 15 psi.

Connect the suction and discharge lines to the fluid end. Open the prime valve (D16-2Y). Open the exhaust petcock valve (D45) by turning handle perpendicular to the flow. Turn on gas flow to the regulator (RM55) and adjust flow to 50 psi on the pressure gauge (D52). The pump should begin stroking around 15 psi. After several strokes, a mixture of air and chemical should be coming from the prime valve hole. Ensure all downstream valves are open. When all the air is ejected from the fluid end, close the prime valve. The pump will now build up discharge pressure. Close the exhaust petcock valve to control flow via the needle valve (D261).

FLOW RATE CONTROL

The chemical injection flow rate can be calculated by counting the strokes per minute and using the provided table.

To adjust the strokes per minute, rotate the needle valve knob (D262). Rotate counterclockwise to increase the exhaust gas flow and increase the stroke rate of the pump. Rotate clockwise to decrease exhaust gas flow and decrease the stroke rate of the pump.

The motive gas pressure can also impact the stroke rate of the pump. Increase the motive gas pressure by rotating the regulator control handle. Increasing pressure will increase the stroke rate of the pump.

Decreasing pressure will decrease the stroke rate of the pump. It is recommended to keep the motive gas pressure between 15 to 60 psi.

The chemical discharge pressure of the pump can impact the stroke rate. Higher discharge pressure will decrease the stroke rate. Lower discharge pressures will increase the stroke rate.

The maximum stroke rate of the pump is 48 strokes per minute. To achieve the maximum stated flow rates, the motive gas inlet pressure should be 60 psi and the pump discharge back pressure should be near 0 psi.

MAINTENANCE & TROUBLESHOOTING

Chemical Leakage: This can be detected by chemical leaking around the packing nut (DFF44) or the vent hole in the bottom casting. To correct this issue, tighten the packing (D12B). Using the supplied packing wrench (D44-3), insert in holes of packing nut and rotate. Hold fluid end steady while rotating the packing nut. The rotation will compress the packing around the piston. Overtightening the packing can impact the pump's performance and decrease the life of the packing. If leak persists, remove fluid end and inspect for worn packing and corroded parts.

Pump Not Stroking: Check for proper motive gas supply to the pump. Open exhaust petcock valve (D45) and open prime valve (D16-2Y). If pump still does not stroke, loosen the packing nut (DFF44). If pump still does not stroke, turn off motive gas supply and remove cap (DFF39). Inspect the location of the diaphragm shaft (DFF3) and spring nut (DFF5). If they are not protruding well above the top plate (DFF1P) as shown in the following DFF pump cutaway illustration, then the pump is stuck in full stroke position.

Pump Stuck In Full Stroke Position: Inspect for a broken spring (D13). Ensure packing (D12B) is not overtightened by loosening the packing nut (DFF44). Inspect for internal corrosion between the guide portion of the piston nut and bottom casting. Ensure the vent hole on the bottom casting is not blocked, which can create a vacuum preventing the piston from stroking.

Pump Operating, Not Moving Chemical: Open prime valve (D16-2Y) and inspect for pump function against atmospheric pressure. If pump is functioning against atmospheric pressure, inspect the inlet check valve (D17Y) for proper sealing. If pump not functioning against atmospheric pressure, inspect the chemical supply to the pump. Inlet lines should be flooded and free flowing into the pump.

Unable to Slow Stroke Rate: Ensure exhaust petcock valve (D45) handle is parallel to the flow of gas in the closed position. Rotate the needle valve knob (D262) clockwise, all the way in. If stroke rate does not slow, inspect for gas leaking from the top plate assembly with soapy water and check for bubbles.

TIPS FOR BEST OPERATION

- Plan ahead for proper pump mounting location
- Short flooded suction lines and clean chemicals with no debris perform best
- Chemical lines should be rigid and have no abrupt change in elevation to prevent trapping gas bubbles
- Fluid end must be vertical for ball check valves to operate properly
- Install a gas cutoff valve before regulator to stop pump instead of using the regulator valve. This will save regulator pressure setting.

DFE #2 PUMP: PARTS LIST

DFE #2	STD	SOUR GAS*
1 FLUID END	***	
2 SPLIT RING	DFE44-1	
3 SPRING	D13	
4 DIAPHRAGM	D9	
5 LOCK WASHER	M4L	
6 NUT	D1-2A	
7 SPACER	D1-3	
8 BOLT	D1-2	
9 BOLT	D1-4	
10 TOP CASTING	DFE1	
11 PLATE	D8	
12 SPRING	DFE7	
13 WASHER	D6	
14 SPRING	D5-1	
15 SPRING NUT	DFE5	DFE5S
16 CAP	DFE39	DFE39S
17 PIN	DFE4	
18 SHAFT	DFE3	DFE3S
19 GAUGE	D52	D52Y
20 REGULATOR	RM55	RM55Q
21 NIPPLE	D54	
22 TUBE	D33A	SST304
23 ADAPTER	D32-2	D32-2Y
24 FLARE NUT	D33-1	
25 CAP, DRIP POT	D27-1	
26 DRIP POT	D27	
27 DRAIN COCK	D45N	
28 STAND	D47-3	
29 BOLT	D1-1	
30 COTTER PIN	D11-2	
31 LINE CHECK VALVE	D461	
32 PACKING WRENCH	D44-3	

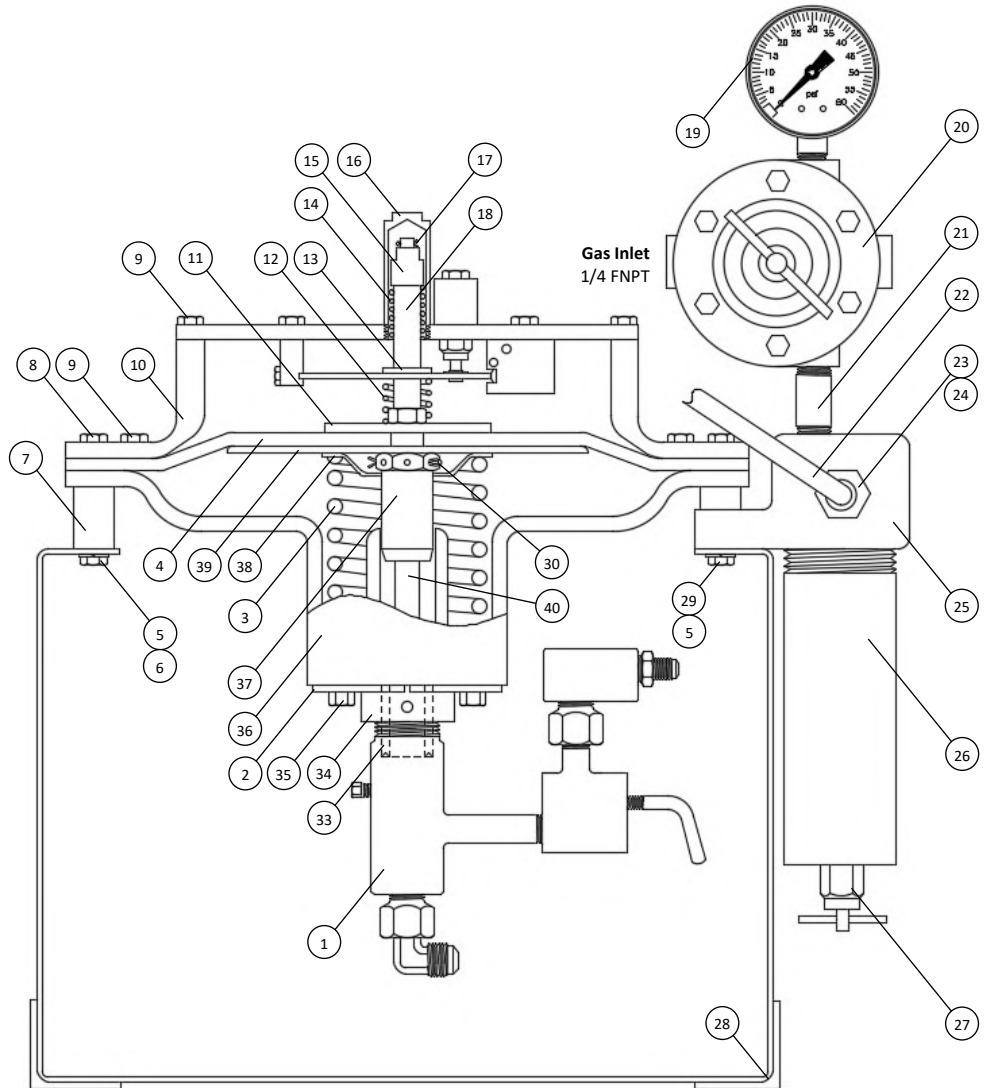

*** See subassembly drawing for part number

*Option replaces brass parts in first column with steel

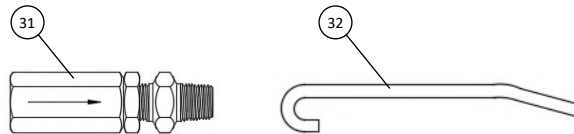

PISTON DIA (IN) MATERIAL	1/4			3/8			3/8 HIGH PRESSURE			5/8		1	
	Standard	Y	Q	Standard	Y	Q	Standard	Y	Q	Y	Q	Standard	Y
33 CYLINDER	D224-1Y	D224-1Y	D224-1Q	-	D224-3Y	D224-3Q	D224-3Y	D224-3Y	D224-3Q	D224-5Y	D224-5Q	DFE121-8Y	DFE121-8Y
34 PACKING NUT	DFE44	DFE44Y	DFE44Y	DFE44	DFE44Y	DFE44Y	DFE441Y	DFE441Y	DFE441Y	DFE441Y	DFE441Y	DFE44-48	DFE44-48Y
35 SCREW	DFE44-2	DFE44-2	DFE44-2	DFE44-2	DFE44-2	DFE44-2	DFE44-6	DFE44-6	DFE44-6	DFE44-2	DFE44-2	DFE44-2	DFE44-2
36 LOWER CASTING	D224A	D224A	D224A	DFE2A	D224A	D224A	DFE2-12A	DFE2-12A	DFE2-12A	DFE221AY	DFE221AY	DFE2-8	DFE2-8
37 PISTON NUT	D11-1	D11-1	D11-1	D11-1	D11-1	D11-1	D11-1	D11-1	D11-1	D111-1	D111-1	DFE11-48	DFE11-48
38 GUIDE WASHER	D14	D14	D14	D14	D14	D14	D14	D14	D14	D14	D14	D14-8	D14-8
39 PLATE	D10	D10	D10	D10	D10	D10	D10-1	D10-1	D10-1	D10	D10	D10	D10
40 PISTON	D114Y	D114Y	D114Q	D11Y	D11Y	D11Q	D11Y	D11Y	D11Q	D111Y	D111Q	DFE11-8Y	DFE11-8Y

All images are for illustrative purposes. Actual product may differ.

DFF #2 PUMP: SUBASSEMBLIES

TOP PLATE ASSY	DFF1PZ	SOUR GAS*
1 BOLT	D1-1	
2 TOP PLATE	DFF1P	
3 GASKET, TOP PLATE	DFF1G	
4 BOLT	LD10-2	
5 PIVOT BLOCK	DFF21	
6 TRIP BAR	DFF20A	
7 SPRING	D20-1	
8 RIVET	D20-2	
9 PUSHROD	DFF40	
10 CAGE, INLET VALVE	DFF40-10	DFF40-10S
11 O-RING, VITON	D46-5V	
12 CAGE, EXHAUST VALVE	DFF43-1	
13 EXHAUST VALVE	DFF43	DFF43-1S
14 ELL	D17-3	D17-3Y
15 GASKET, VALVE BLOCK	DFF25G	
16 VALVE BLOCK	DFF25	DFF25S
17 BALL, CERAMIC	D17-5C	
18 SPRING	DFF42	
19 SPRING RETAINER PLUG	DFF42-1	DFF42-1S
SNAP CUBE ASSY	DFF50Z	
20 BEARING	D23-1	
21 BEARING PIN	DFF23P	
22 HANGER	DFF23	DFF23S
23 WASHER	DFF23-5A	
24 SPRING	D24	
25 SNAP CUBE	DFF50	
26 RETAINING RING	D51	
27 HANGER PIN	DFF50-1	
CONTROL ASSY	D502Z	
28 PETCOCK VALVE	D45	D45S
29 TEE, TUBE	D32	
30 CONTROL TUBE	D501B	
31 SPRING	D501A	
32 CONTROL NEEDLE	D261	
33 SETSCREW	M20-5	
34 KNOB	D262	
35 NIPPLE	D54	

*Option replaces brass parts in first column with steel

DFF1PZ does not include D502Z

DFF50Z and D502Z can be purchased individually

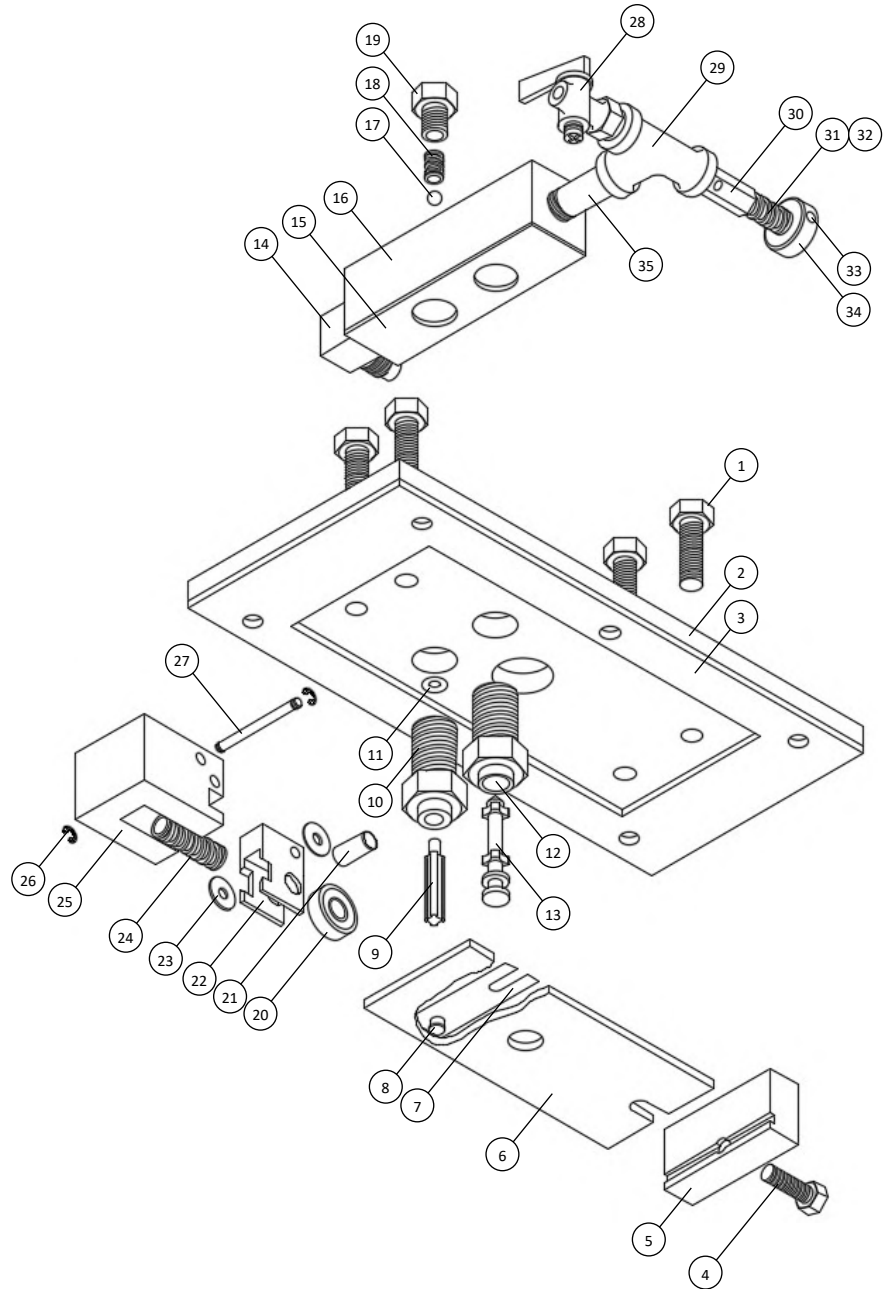

LINE CHECK VALVE	D461	D462Q
1 BODY / CAGE	D461B	D176BQ
2 O-RING, TEFLON™	M170-55T*	D170-5T*
3 RING	D461R	D177
4 BALL, CERAMIC	D17-5C	D17-6C
5 SPRING	D461S	D178
6 SPRING	D18-1Y	D462SQ
7 NIPPLE / BODY	D461A	D462BFQ

*Alternate materials: Buna-N, Viton™, Neoprene, EPDM

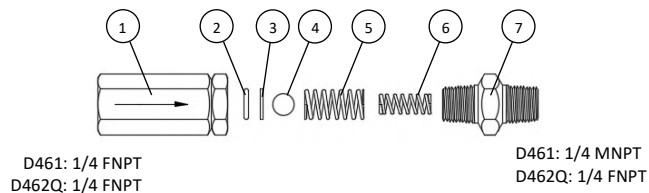

All images are for illustrative purposes. Actual product may differ.

DFE #2 PUMP: SUBASSEMBLIES CONTINUED

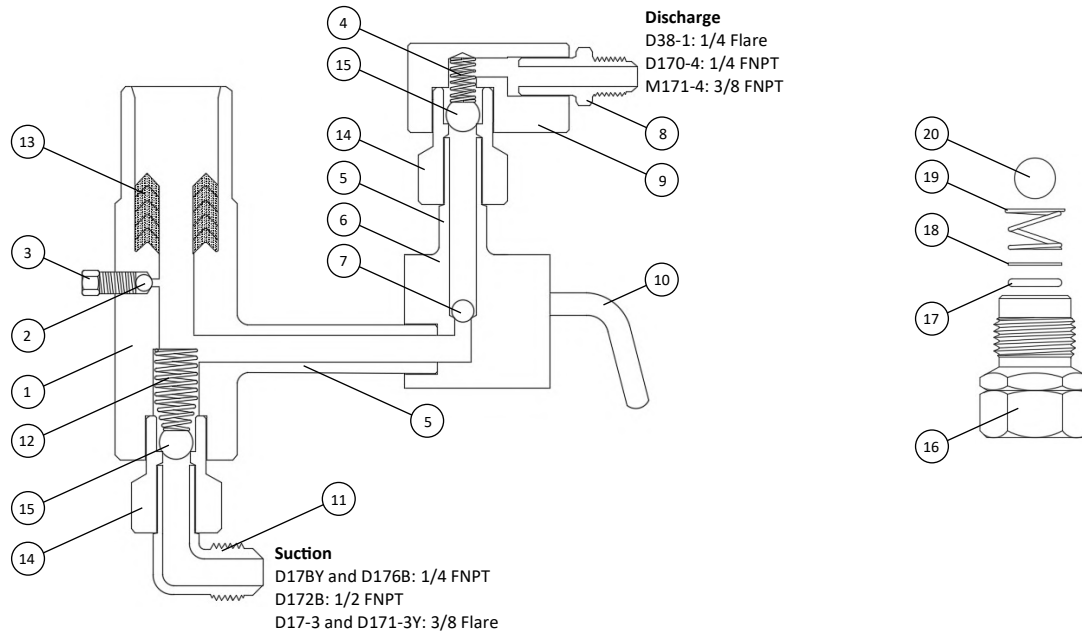

UPGRADE:
Resilient check valve improves sealing capability on low viscosity fluids such as methanol

PISTON DIA (IN) MATERIAL	1/4			3/8			3/8 HIGH PRESSURE			5/8		1	
	Standard	Y	Q	Standard	Y	Q	Standard	Y	Q	Y	Q	Standard	Y
FLUID END ASSY	D154Z1	D154Z1Y	D154Z1Q	D15Z1	D15Z1Y	D15Z1Q	D15A-12Z1	D15A-12Z1Y	D15A-12Z1Q	D151Z1Y	D151Z1Q	DFE158Z1	DFE158Z1Y
1 FLUID END BODY	D154	D154Y	D154Q	D15	D15Y	D15Q	D15A-12	D15A-12Y	D15A-12Q	D151Y	D151Q	DFE158	DFE158Y
2 BLEED BALL, TUNGSTEN	D17-3T	D17-3T	D17-3T	D17-3T	D17-3T	D17-3T	D17-4T	D17-4T	D17-4T	D17-3T	D17-3T	D17-3T	D17-3T
3 BLEED PLUG	D154Y-B	D154Y-B	D154Q-B	D154Y-B	D154Y-B	D154Q-B	D15C-12Y	D15C-12Y	D15C-12Q	D154Y-B	D154Q-B	D154Y-B	D154Y-B
4 DISCHARGE SPRING	D18-1Y	D18-1Y	D18-1Y	D18-1Y	D18-1Y	D18-1Y	D18-1Y	D18-1Y	D18-1Y	D18-1Y	D18-1Y	M181-1Y	M181-1Y
5 NIPPLE	-	-	-	-	-	-	D15B-12	D15B-12Y	D15B-12Q	-	-	DFE161-8Y	DFE161-8Y
6 DISCHARGE BLOCK	DFE160	DFE160Y	DFE160Q	DFE160	DFE160Y	DFE160Q	D160A12	D160A12Y	D160A12Q	DFE160Y	DFE160Q	DFE160-8	DFE160-8Y
7 PRIME BALL, CERAMIC	D17-4C	D17-4C	D17-4C	D17-4C	D17-4C	D17-4C	D17-4C*	D17-4C*	D17-4C*	D17-4C	D17-4C	D171-2C	D171-2C
7 PRIME BALL, TUNGSTEN	D17-4T*	D17-4T*	D17-4T*	D17-4T*	D17-4T*	D17-4T*	D17-4T	D17-4T	D17-4T	D17-4T*	D17-4T*	D171-2T*	D171-2T*
8 DISCHARGE ADAPTER	D38-1	-	-	D38-1	-	-	D38-1S	-	-	-	-	-	-
9 SQUARE ELL	D170-4	D170-4Y	D170-4Q	D170-4	D170-4Y	D170-4Q	D170-4	D170-4Y	D170-4Q	D170-4Y	D170-4Q	M171-4	M171-4Y
10 PRIME VALVE	D16-2Y	D16-2Y	D16-2Q	D16-2Y	D16-2Y	D16-2Q	D16-2Y	D16-2Y	D16-2Q	D16-2Y	D16-2Q	D16-2Y	D16-2Y
11 INLET ADAPTER	D17-3	D17-3Y*	-	D17-3	D17-3Y*	-	D17-3	D17-3Y*	-	D171-3Y*	-	D171-3Y*	D171-3Y*
12 SPRING	D17-1	D17-1	D17-1	D17-1	D17-1	D17-1	D17-1	D17-1	D17-1	D171-1	D171-1Q	D171-1	D171-1
PIN	-	-	-	-	-	-	-	-	-	-	-	DFE8-D	DFE8-D
PLUG, DISCHARGE	-	-	-	-	-	-	-	-	-	-	-	DFE160-8AY	DFE160-8AY
13 V-RING PACKING	HHHHH	BTBTB	VTVTV	HHHHH	BTBTB	VTVTV	XXX	XXX	XXX	BTBTB	VTVTV	HTH	BTB
PACKING, EPDM (B)	D124B*	D124B (3)	D124B*	D12B*	D12B (3)	D12B*	-	-	-	D121B (3)	D121B*	M121-8B*	M121-8B (2)
PACKING, BUNA-N (H)	D124H (5)	D124H*	D124H*	D12H (5)	D12H*	D12H*	-	-	-	D121H*	D121H*	M121-8H (2)	M121-8H*
PACKING, NEOPRENE (N)	D124N*	D124N*	D124N*	D12N*	D12N*	D12N*	-	-	-	D121N*	D121N*	M121-8N*	M121-8N*
PACKING, TEFLON™ (T)	D124T*	D124T (2)	D124T (2)	D12T*	D12T (2)	D12T (2)	-	-	-	D121T (2)	D121T (2)	M121-8T (1)	M121-8T (1)
PACKING, VITON™ (V)	D124V*	D124V*	D124V (3)	D12V*	D12V*	D12V (3)	-	-	-	D121V*	D121V (3)	M121-8V*	M121-8V*
ARAMID COMPOSITE	-	-	-	-	-	-	D12HP (3)	D12HP (3)	D12HP (3)	-	-	-	-
CHECK VALVE	D17Y	D17Y	D17Q	D17Y	D17Y	D17Q	-	-	-	D172Y	D172Q	D172Y	D172Y
14 CAGE	D17BY	D17BY	D17BQ	D17BY	D17BY	D17BQ	-	-	-	D172B	D172BQ	D172B	D172B
15 CHECK BALL, CERAMIC	D17-6C	D17-6C	D17-6C	D17-6C	D17-6C	D17-6C	-	-	-	D171-2C	D171-2C	D171-2C	D171-2C
15 CHECK BALL, TUNGSTEN	D17-6T*	D17-6T*	D17-6T*	D17-6T*	D17-6T*	D17-6T*	-	-	-	D171-2T*	D171-2T*	D171-2T*	D171-2T*
RESILIENT CHECK VALVE	D176ZYT*	D176ZYT*	D176ZQT*	D176ZYT*	D176ZYT*	D176ZQT*	D176ZYT	D176ZYT	D176ZQT	D172ZYT	D172ZQT	D172ZYT	D172ZYT
16 CAGE	D176B	D176B	D176BQ	D176B	D176B	D176BQ	D176B	D176B	D176BQ	D172B	D172BQ	D172B	D172B
17 O-RING, TEFLON™	D170-5T**	D170-5T**	D170-5T**	D170-5T**	D170-5T**	D170-5T**	D170-5T**	D170-5T**	D170-5T**	D171-8T**	D171-8T**	D171-8T**	D171-8T**
18 RING	D177	D177	D177	D177	D177	D177	D177	D177	D177	D173	D173	D173	D173
19 SPRING	D178	D178	D178	D178	D178	D178	D178	D178	D178	D174	D174	D174	D174
20 CHECK BALL, CERAMIC	D17-6C	D17-6C	D17-6C	D17-6C	D17-6C	D17-6C	D17-6C	D17-6C	D17-6C	D171-2C	D171-2C	D171-2C	D171-2C
20 CHECK BALL, TUNGSTEN	D17-6T*	D17-6T*	D17-6T*	D17-6T*	D17-6T*	D17-6T*	D17-6T*	D17-6T*	D17-6T*	D171-2T*	D171-2T*	D171-2T*	D171-2T*

*Optional equipment, please specify when ordering
**Alternate materials: Buna-N, Viton™, Neoprene, EPDM

All images are for illustrative purposes. Actual product may differ.

DFE #1 PUMP: PARTS LIST

Includes all parts from DFE #2

DFE #1	
1	TUBE ASSY D33
2	BOLT DFF44-2
3	LOCK WASHER D47-1L
4	WASHER M56
5	NUT D47-1A
6	BRACKET D47H1
7	BOLT D47-1C
TANK ASSY D48ZY	
8	TANK VALVE ASSY D29
8	TANK VALVE ASSY D29Y*
9	TANK D48Y
10	GAUGE STICK D49
11	TANK LID WITH KNOB D48-1Y
NOT PICTURED	
	LEVEL SIGHT GAUGE 929-1-S*

*Optional equipment

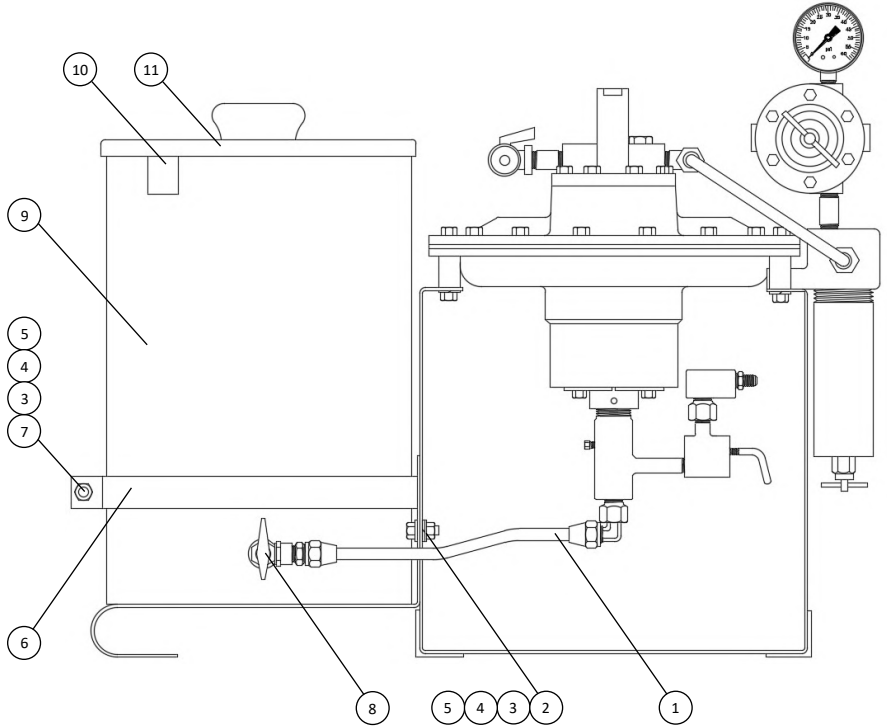

TANK VALVE ASSY	D29	D29Y
1	ADAPTER D32-2	D17-3Y
2	BALL VALVE D29V	D29VY
3	ADAPTER D29A	D29AY
4	GASKET D28-8	D28-8
5	NUT D28-4Y	D28-4Y
6	STRAINER D28-3	D28-3

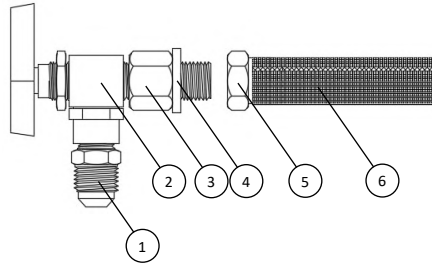

DFE OPTION: EXHAUST GAS RECOVERY

EXHAUST GAS RECOVERY	EG101
1	KNOB D62
2	SETSCREW M20-5
3	SPRING D501A
4	NEEDLE D61
5	O-RING, VITON D143V
6	INLET VALVE BLOCK DFF35
7	TEE D32
8	TUBE ASSY D63
9	ADAPTER D32-2
10	NIPPLE D64
11	ELL D59
12	PETCOCK D55
13	TUBE ASSY D73
14	ELL D67
15	VALVE BODY DFF55
16	GLAND NUT DFF45
17	O-RING, VITON D414V

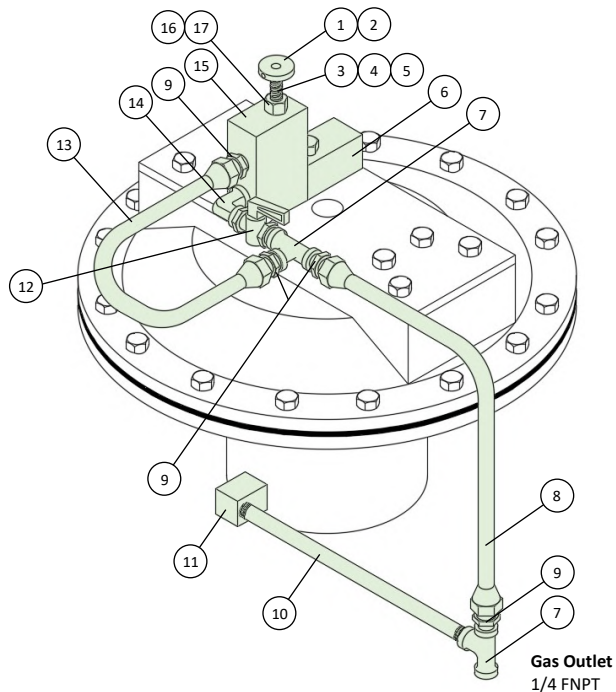

All images are for illustrative purposes. Actual product may differ.

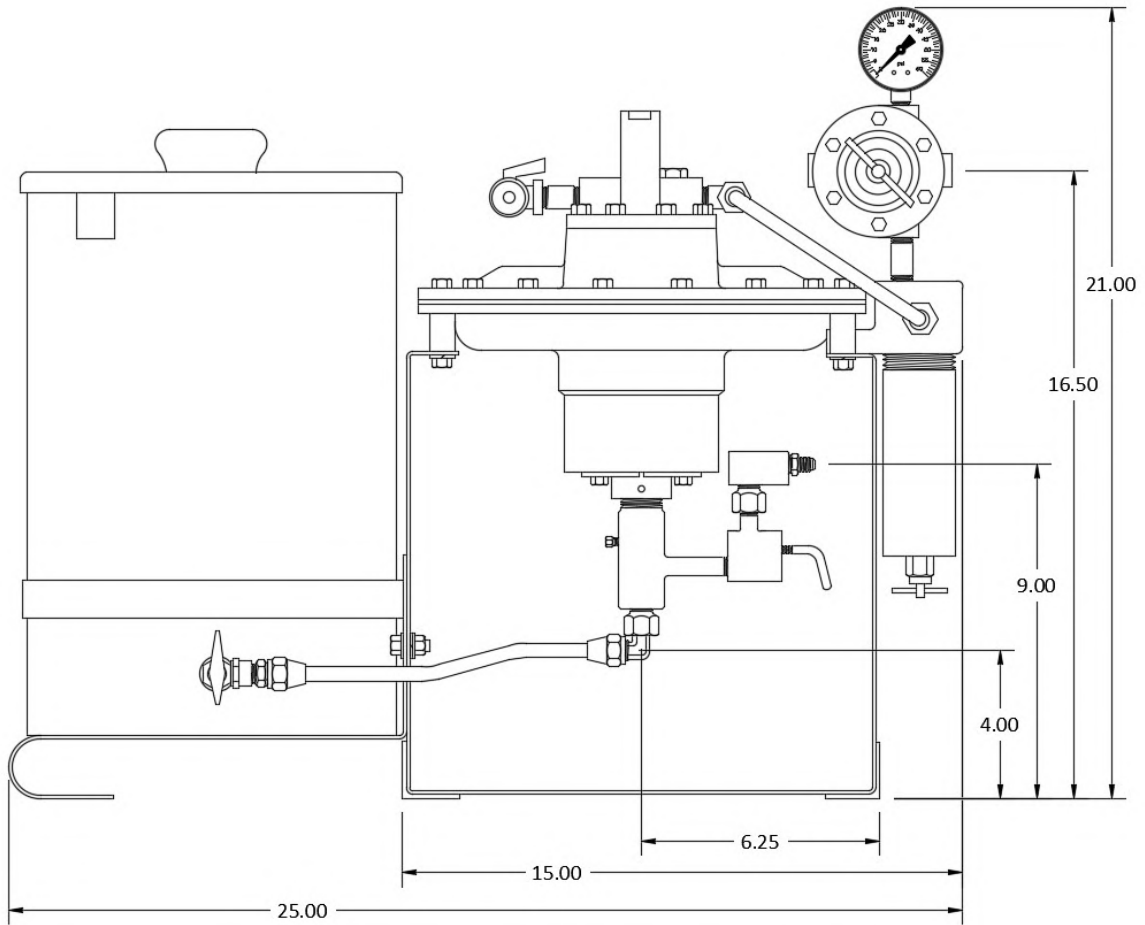
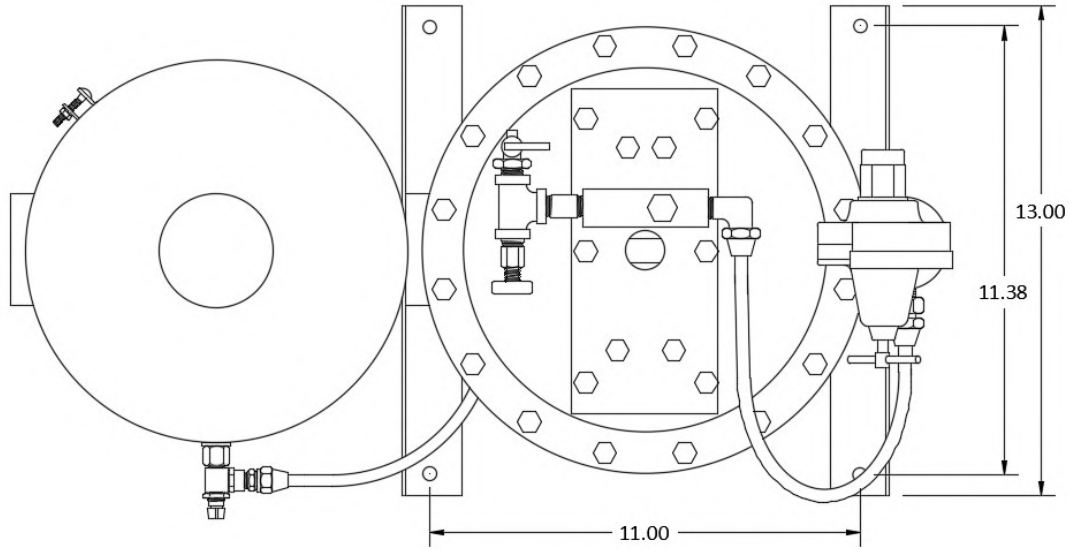

DFP

Western Chemical Pumps, Inc.
 603 South Kansas Avenue, Olathe, KS 66061
 913 - 829 - 1888 | sales@westernchemicalpumps.com

Dimensions are in inches. Actual product may have variance in measurements.
 All images are for illustrative purposes. Actual product may differ.

Western Chemical Pumps, Inc. reserves the right to make changes in specifications and features shown herein, or discontinue the product described at any time without notice or obligation. Contact your Western Chemical Pumps, Inc. distributor for the most current information.