

CHEMICAL INJECTION PUMP

MOTOR DRIVEN

MULTI HEAD

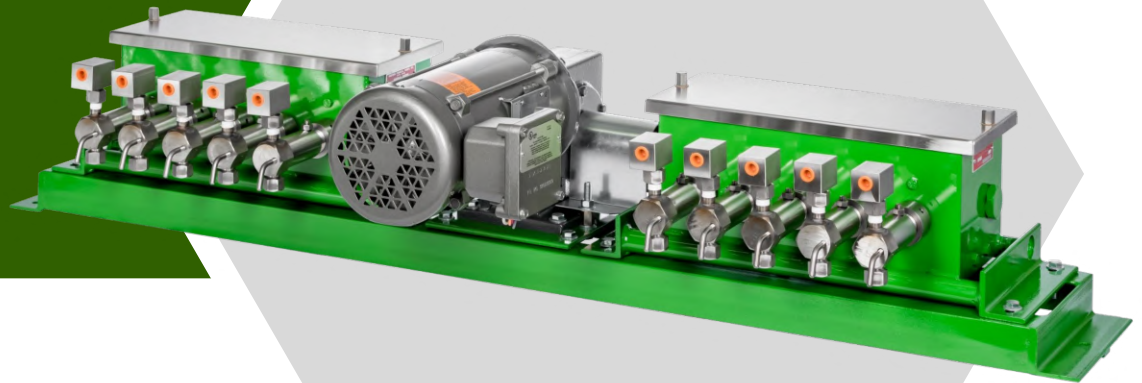

MH

The model MH chemical injection pumps are designed to be driven by an electric motor. These positive displacement pumps have removable fluid ends with interchangeable check valves, and a removable stainless steel cover for easy maintenance on the drivetrain.

These multi head pumps accommodate 1-10 fluid ends providing higher flow rates or the ability to pump multiple different chemicals simultaneously. These pumps are expandable for future needs up to a maximum of 10 fluid ends and are available in various materials and piston sizes to meet your specific chemical injection requirements.

For decades, Western Chemical Pumps model MH pump has demonstrated reliable engineering and design, earning the trust of its users through rigorous testing and proven performance.

FEATURES

- ◆ 1 to 10 fluid end pump
- ◆ Simple dial controlled chemical injection flow rate for each individual fluid end
- ◆ Add on fluid ends when needed up to a max of 10 fluid ends
- ◆ Double piston seals with vented isolation to prevent chemical blow-by into pump box
- ◆ Capable of injecting up to 4,500 psi
- ◆ Stainless steel piston and check valves come standard for longer life

WESTERN

TM



MH PUMP CONFIGURATIONS

2MH	10	Y	.250	PART NUMBER
↑	↑	↑	↑	Model
2MH				Electric Motor, Multi Head
				Number of Fluid Ends
	3			3 - (5 Fluid End Pump Box)
	4			4 - (5 Fluid End Pump Box)
	5			5 - (5 Fluid End Pump Box)
	6			6 - (10 Fluid End Pump Box)
	7			7 - (10 Fluid End Pump Box)
	8			8 - (10 Fluid End Pump Box)
	9			9 - (10 Fluid End Pump Box)
	10			10 - (10 Fluid End Pump Box)
				Fluid End Material
				Steel (standard)
		Y		Stainless Steel
		Q		316 Stainless Steel
				Piston Diameter
			.250	1/4"
			.375	3/8"

OPTIONS & UPGRADES

Material: Upgrade to Y or Q models for enhanced corrosion resistance

Piston Size: Multiple sizes available to fit your required injection flow rates and pressures

Resilient Seat Check Valves: Added O-ring provides better sealing capability, which is ideal for low viscosity fluids, such as methanol

Packing Seals: Buna-N, EPDM, Neoprene, PTFE (Teflon™), FKM (Viton™)

Rope Packing: Graphite impregnated or PTFE (Teflon™) rope

Prime Ball: Ceramic or tungsten

Motors: Multiple motor models available to fit your power supply

Coupler: Option available that is ideal for cold weather environments

Other unique or special order materials are available to fit your needs. Please inquire with your Western Chemical Pumps, Inc. distributor. Specify desired options when placing order.

PER HEAD			
PISTON DIA (IN)	# OF FLUID ENDS	MAX DISCHARGE PRESSURE (PSI)	FLOW RATE MIN - MAX (QTS / DAY)
1/4	5 or less	4,500	0 - 24.0
3/8	5 or less	2,000	0 - 55.0
1/4	6 or more	2,250	0 - 24.0
3/8	6 or more	1,000	0 - 55.0

PER HEAD		
FLOW RATE (QTS/ DAY)		
FLOW CONTROL DIAL ROTATIONS	1/4" PISTON	3/8" PISTON
1/2	0.6	1.4
3/4	0.9	2.0
1	1.2	2.8
2	2.4	5.5
3	3.6	8.3
4	4.8	11.0
8	9.6	22.0
12	14.4	33.0
16	19.2	44.0
20	24.0	55.0

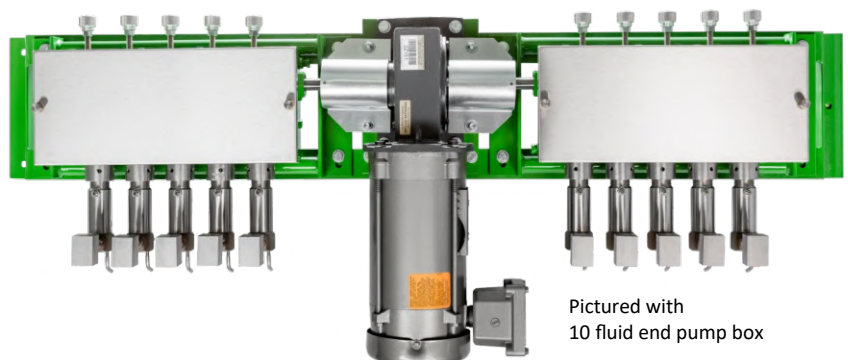
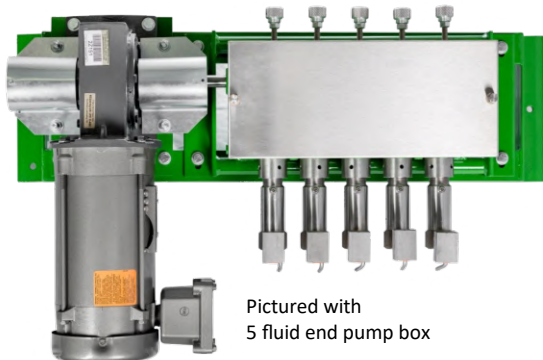

CAUTION

3 PHASE MOTORS REVERSE DIRECTION WHEN POWER WIRES ARE INTERCHANGED. CHECK ROTATION OF MOTOR IMMEDIATELY AFTER ANY ELECTRICAL MODIFICATIONS.

ENSURE PUMP IS ELECTRICALLY ISOLATED WITH PROPER LOCKOUT / TAGOUT PROCEDURES PRIOR TO PERFORMING WORK.

ENSURE CHECK VALVE FLOW IS IN THE DIRECTION OF THE ARROW. INCORRECT DIRECTION COULD CAUSE PUMP TO OVER PRESSURE.

INSTALLATION & OPERATION

Securely mount base (MH1, MH1-10) to concrete pad or platform. Ensure motor and pump shaft remain in alignment during installation. Misalignment could cause premature wear on coupler and bearings.

Fill the pump box with SAE 20 or SAE 30 oil. The oil level should partially submerge the piston.

Connect the motor to power following the wiring instructions printed on the motor.

Connect the suction and discharge lines to the fluid end. Adjust the flow control dial to the maximum stroke length during priming. Open the prime valve (D16-2Y) and run the pump until gas is purged from the system. Bubbles and chemical may flow out of the prime valve opening. If trouble is experienced during priming, use a trigger type oil can to force oil through the bleed hole into the fluid end. This may speed up the priming process. Close the prime valve after priming is complete.

FLOW RATE CONTROL

The flow rate can be adjusted from no stroke to full stroke in fine increments by rotating the flow control dial. Rotate the flow control dial clockwise (in) to decrease the flow rate and counterclockwise (out) to increase the flow rate.

To set an approximated flow rate, turn flow control dial clockwise (in) just until the bearing (M8) lifts off the camshaft (MH8) and the piston has no travel. Every rotation counterclockwise (out) will increase the flow rate. By counting the number of counterclockwise rotations and using the provided flow rate table, an approximate flow rate can be set. There are 20 rotations of the flow control dial from no stroke to full stroke of the piston.

MAINTENANCE & TROUBLESHOOTING

Chemical Leakage: This can be detected by chemical leaking around the fluid end nut (LD12-4B). To correct this issue, tighten the V-ring packing (D12B). First, loosen the setscrew (LD12-2) and nut (D47-1A) on top of the fluid end. Using the supplied packing wrench (D44-3), insert in holes of fluid end nut and rotate. Hold fluid end upright while rotating the fluid end nut. The rotation will compress the V-ring packing around the piston. Tighten the setscrew and nut on top of the fluid end. Overtightening the V-ring packing can prevent the piston from completing a full stroke.

Preventing Pump Box Oil Leakage Into Fluid End: This can be detected by oil leaking around the fluid end nut (LD12-4B). To correct this issue, tighten the rope packing (LD15-1). First, remove the cover (MH2-2) of the pump. Using the packing wrench (D44-3), insert in holes of packing nut (LD15Y) and rotate. Do not overtighten rope packing.

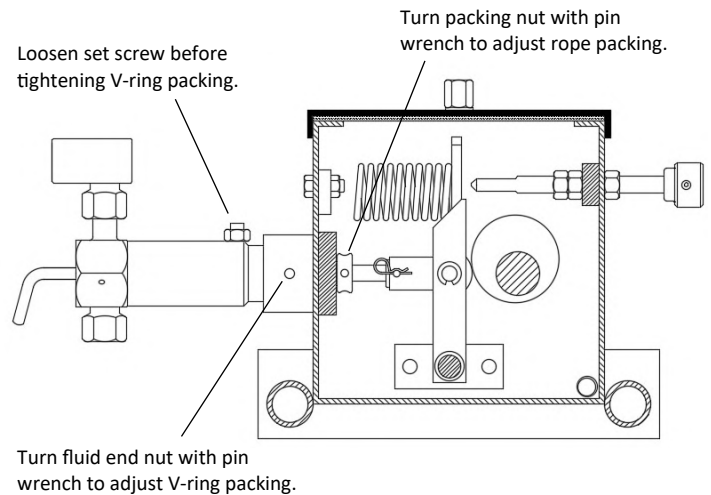

TIPS FOR BEST OPERATION

- Plan ahead for proper pump mounting location
- Short flooded suction lines and clean chemicals with no debris perform best
- Chemical lines should be rigid and have no abrupt change in elevation to prevent trapping gas bubbles
- Fluid end must be vertical for ball check valves to operate properly
- Keep pump and motor shaft properly aligned
- Install motor cutoff switch within easy reach of pump
- Keep oil clean and at the recommended fill level to partially submerge piston

All images are for illustrative purposes. Actual product may differ.

2MH PUMP: PARTS LIST

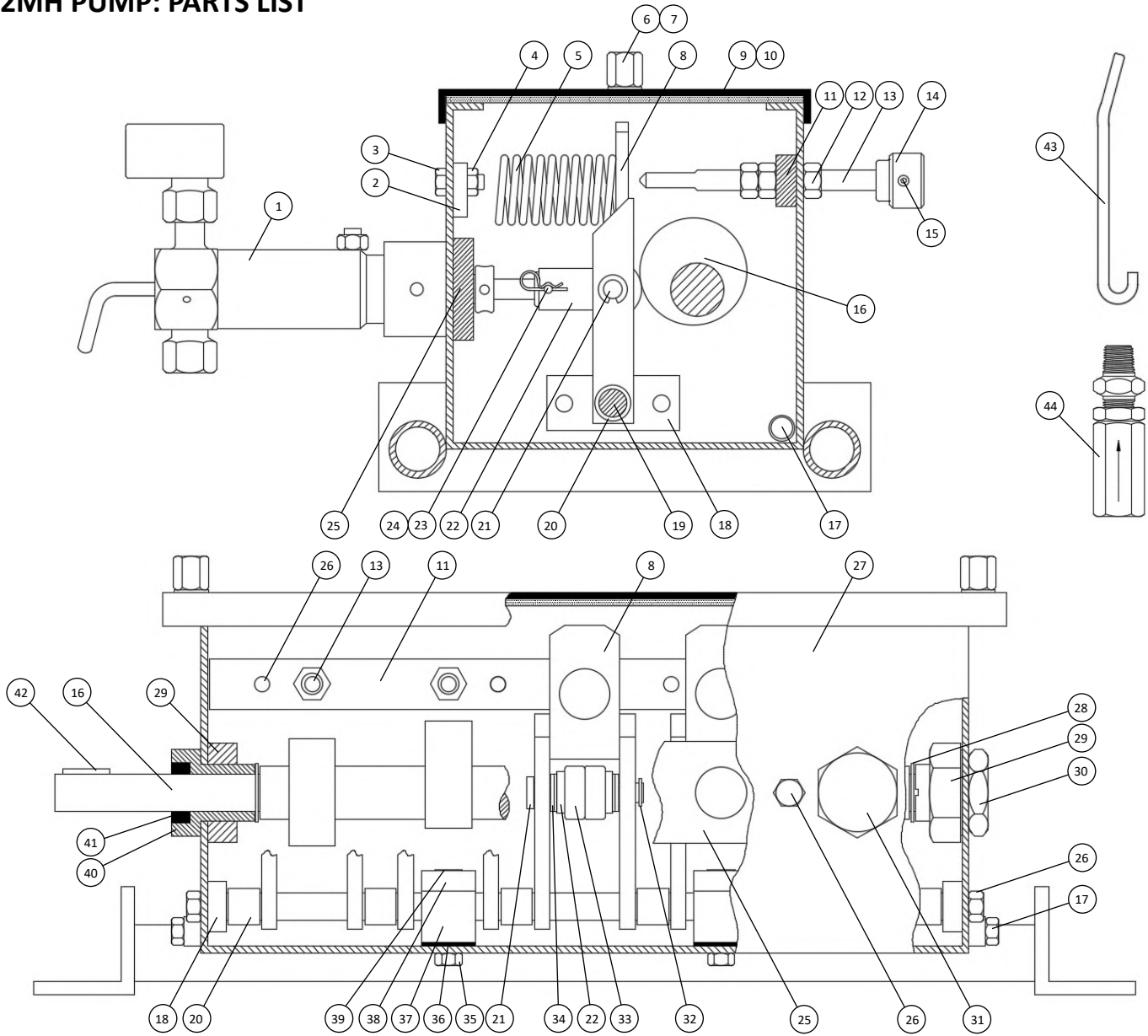

2MH							
1 FLUID END	***	12 NUT	D1-2A	23 PIN	MH13-1	34 SPACER	LD5-3M
2 SLUG	LD10-1	13 CONTROL SCREW	LD7	24 COTTER PIN	LD13-2	35 SCREW	MH5-1H
3 SCREW	M13-1	14 KNOB	LD7-1	25 CYLINDER BAR	MH12-5	36 GASKET	MH5-1G
4 NUT	M26-1B	15 SETSCREW	LD7-1A	26 BOLT	DFF44-2	37 PIVOT RETAINER	MH5-1D
5 SPRING	MH100	16 CAMSHAFT	MH8	27 PUMP BOX	MH2	38 PIVOT HOLD	MH5-1E
6 THUMB SCREW	LD23-2	17 DRAIN PLUG	M2-2	28 SHIM WASHER	M6-2W	39 SCREW	MH5-1F
7 GASKET	LD23-2A	18 BEARING BLOCK	MH5-1B	29 NUT	MH9-4	40 BEARING RETAINER	MH9A
8 YOKE	MH5M	19 PIVOT SHAFT	MH5-1	30 BEARING CAP	MH9-1	41 SEAL	MH9-2A
9 GASKET	MH2-2A	20 SPACER	MH5-1C	31 PLUG	MH12-6	42 KEY	MH10-1
10 COVER	MH2-2B	21 SHAFT	MH5-2M	32 RETAINING RING	M20D4	43 PACKING WRENCH	D44-3
11 CONTROL SCREW BAR	MH7-4	22 LINK	MH13M	33 BEARING	LD6M	44 LINE CHECK VALVE	D461

Subassembly detail shown in following drawings

*** See subassembly drawing for part number

All images are for illustrative purposes. Actual product may differ.

2MH PUMP: PARTS LIST CONTINUED

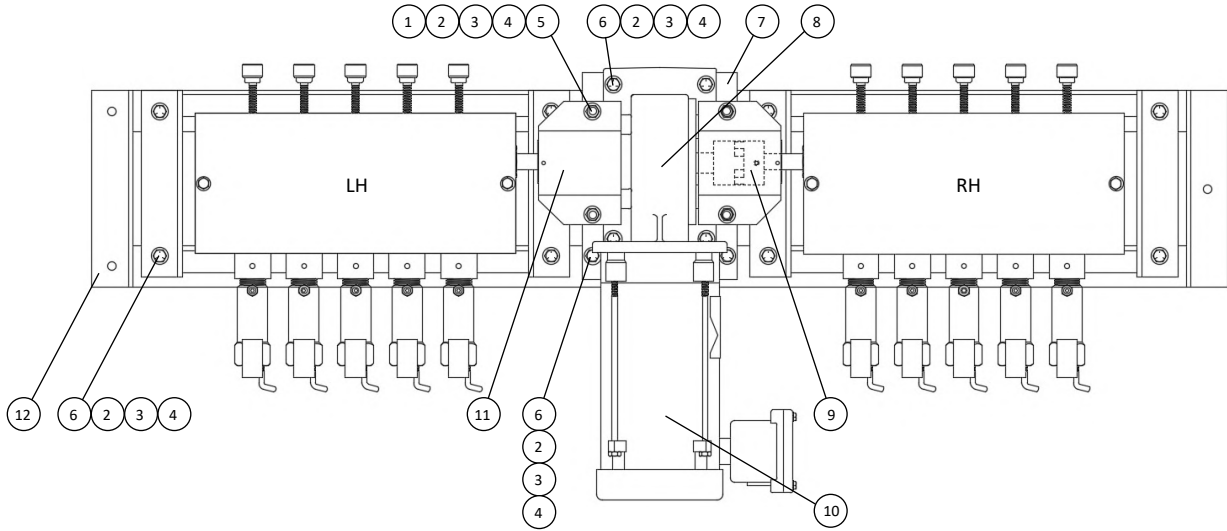

2MH	
1 BOLT	D1-2
2 LOCK WASHER	M4L
3 WASHER	D21-2
4 NUT 3/8	D1-2A
5 DOUBLE NUT	MH10-3
6 BOLT	LD8-3
7 PLATE	MH1A
8 GEAR REDUCER	MHRDC1
9 COUPLING	MH10
10 MOTOR	***
11 COUPLING GUARD	MH10-2
12 10HD FRAME	MH1-10
13 5HD FRAME	MH1
14 SCREW	MH10-5
15 COUPLING GUARD END	MH10-4

*** See motor table for part number

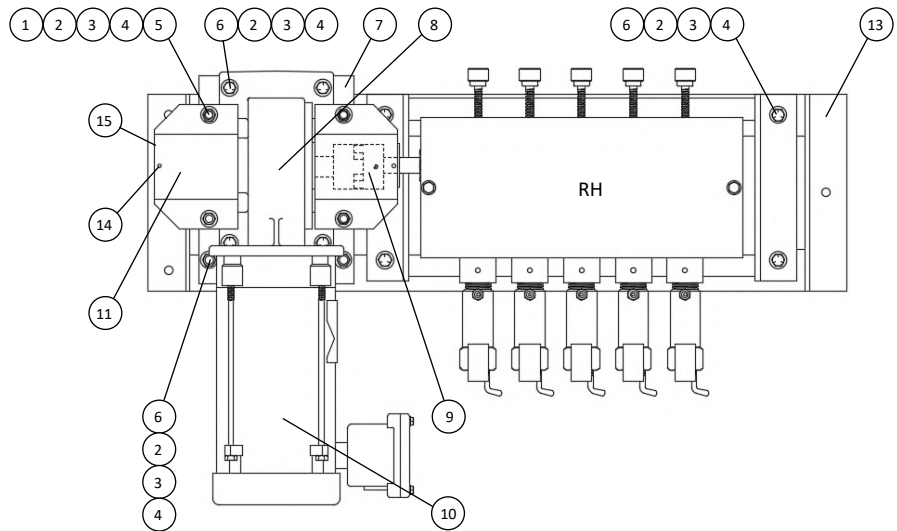

MOTOR	HP	HZ	VOLTAGE	PHASE	ENCLOSURE	HAZARD CLASS	TEMP CODE
MR-T12C	1/2	60	115/208-230V AC	1	TEFC	-	-
MR-T32C	1/2	60	208/230-460V AC	3	TEFC	-	-
MR-E12C	1/2	60	115/208-230V AC	1	XPFC	CL 1 GR C,D / CL 2 GR E,F,G	T3B
MR-E32C	1/2	60	208/230-460V AC	3	XPFC	CL 1 GR D / CL 2 GR F,G	T3C

2MH PUMP: SUBASSEMBLIES

LINE CHECK VALVE	D461	D462Q
1 BODY / CAGE	D461B	D176BQ
2 O-RING, TEFLON™	M170-55T*	D170-5T*
3 RING	D461R	D177
4 BALL, CERAMIC	D17-5C	D17-6C
5 SPRING	D461S	D178
6 SPRING	D18-1Y	D462SQ
7 NIPPLE / BODY	D461A	D462BFQ

*Alternate materials: Buna-N, Viton™, Neoprene, EPDM

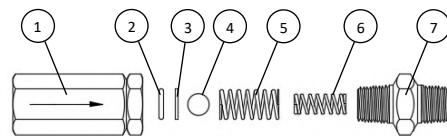

D461: 1/4 FNPT
D462Q: 1/4 FNPT

D461: 1/4 MNPT
D462Q: 1/4 FNPT

All images are for illustrative purposes. Actual product may differ.

2MH PUMP: SUBASSEMBLIES CONTINUED

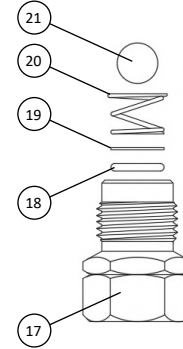
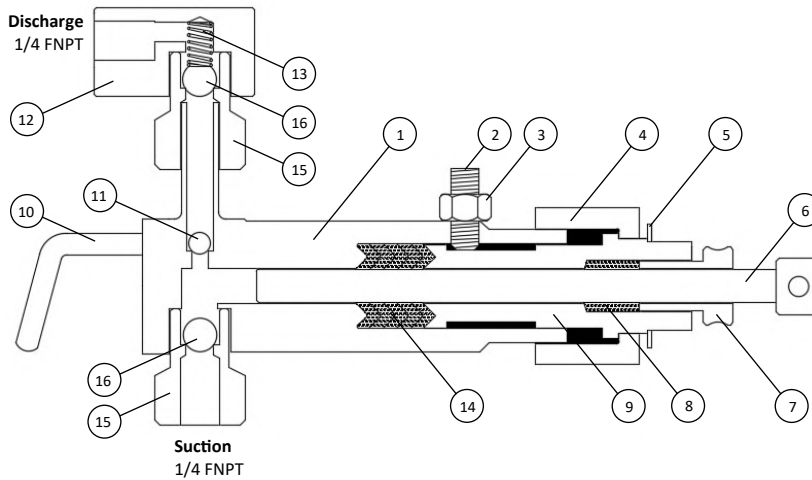

UPGRADE:
Resilient check valve improves sealing capability on low viscosity fluids such as methanol

PISTON DIA (IN) MATERIAL	1/4			3/8		
	Standard	Y	Q	Standard	Y	Q
MH FLUID END ASSY	MH164Z1	MH164Z1Y	MH164Z1Q	MH160Z1	MH160Z1Y	MH160Z1Q
1 FLUID END BODY	LD164	LD164Y	LD164Q	LD160	LD160Y	LD160Q
2 SETSCREW	LD12-2	LD12-2Q	LD12-2Q	LD12-2	LD12-2Q	LD12-2Q
3 NUT	D47-1A	D47-1AQ	D47-1AQ	D47-1A	D47-1AQ	D47-1AQ
4 FLUID END NUT	LD12-4B	LD12-4BY	LD12-4BQ	LD12-4B	LD12-4BY	LD12-4BQ
5 GASKET	LD12-1	LD12-1	LD12-1	LD12-1	LD12-1	LD12-1
6 PISTON	MH144Y	MH144Y	MH144Q	MH14Y	MH14Y	MH14Q
7 ROPE PACKING NUT	LD15Y	LD15Y	LD15Q	LD15Y	LD15Y	LD15Q
8 ROPE PACKING, GRAPHITE	LD15-1	LD15-1	LD15-1*	LD15-1	LD15-1	LD15-1*
8 ROPE PACKING, TEFLON™	LD15-1T*	LD15-1T*	LD15-1T	LD15-1T*	LD15-1T*	LD15-1T
9 CYLINDER	LD124-4AY	LD124-4AY	LD124-4AQ	LD12-4AY	LD12-4AY	LD12-4AQ
10 PRIME VALVE	D16-2Y	D16-2Y	D16-2Q	D16-2Y	D16-2Y	D16-2Q
11 PRIME BALL, CERAMIC	D17-4C	D17-4C	D17-4C	D17-4C	D17-4C	D17-4C
11 PRIME BALL, TUNGSTEN	D17-4T*	D17-4T*	D17-4T*	D17-4T*	D17-4T*	D17-4T*
12 SQUARE ELL	D170-4	D170-4Y	D170-4Q	D170-4	D170-4Y	D170-4Q
13 SPRING	D18-1Y	D18-1Y	D18-1Y	D18-1Y	D18-1Y	D18-1Y
14 V-RING PACKING	HHHHH	BTBTB	VTVTV	HHHHH	BTBTB	VTVTV
PACKING, EPDM (B)	D124B*	D124B (3)	D124B*	D12B*	D12B (3)	D12B*
PACKING, BUNA-N (H)	D124H (5)	D124H*	D124H*	D12H (5)	D12H*	D12H*
PACKING, NEOPRENE (N)	D124N*	D124N*	D124N*	D12N*	D12N*	D12N*
PACKING, TEFLON™ (T)	D124T*	D124T (2)	D124T (2)	D12T*	D12T (2)	D12T (2)
PACKING, VITON™ (V)	D124V*	D124V*	D124V (3)	D12V*	D12V*	D12V (3)
CHECK VALVE	D17Y	D17Y	D17Q	D17Y	D17Y	D17Q
15 VALVE CAGE	D17BY	D17BY	D17BQ	D17BY	D17BY	D17BQ
16 CHECK BALL, CERAMIC	D17-6C	D17-6C	D17-6C	D17-6C	D17-6C	D17-6C
16 CHECK BALL, TUNGSTEN	D17-6T*	D17-6T*	D17-6T*	D17-6T*	D17-6T*	D17-6T*
RESILIENT CHECK VALVE	D176ZYT*	D176ZYT*	D176ZQT*	D176ZYT*	D176ZYT*	D176ZQT*
17 CAGE	D176B	D176B	D176BQ	D176B	D176B	D176BQ
18 O-RING, TEFLON™	D170-5T**	D170-5T**	D170-5T**	D170-5T**	D170-5T**	D170-5T**
19 RING	D177	D177	D177	D177	D177	D177
20 SPRING	D178	D178	D178	D178	D178	D178
21 CHECK BALL, CERAMIC	D17-6C	D17-6C	D17-6C	D17-6C	D17-6C	D17-6C
21 CHECK BALL, TUNGSTEN	D17-6T*	D17-6T*	D17-6T*	D17-6T*	D17-6T*	D17-6T*

*Optional equipment, please specify when ordering

**Alternate materials: Buna-N, Viton™, Neoprene, EPDM

All images are for illustrative purposes. Actual product may differ.

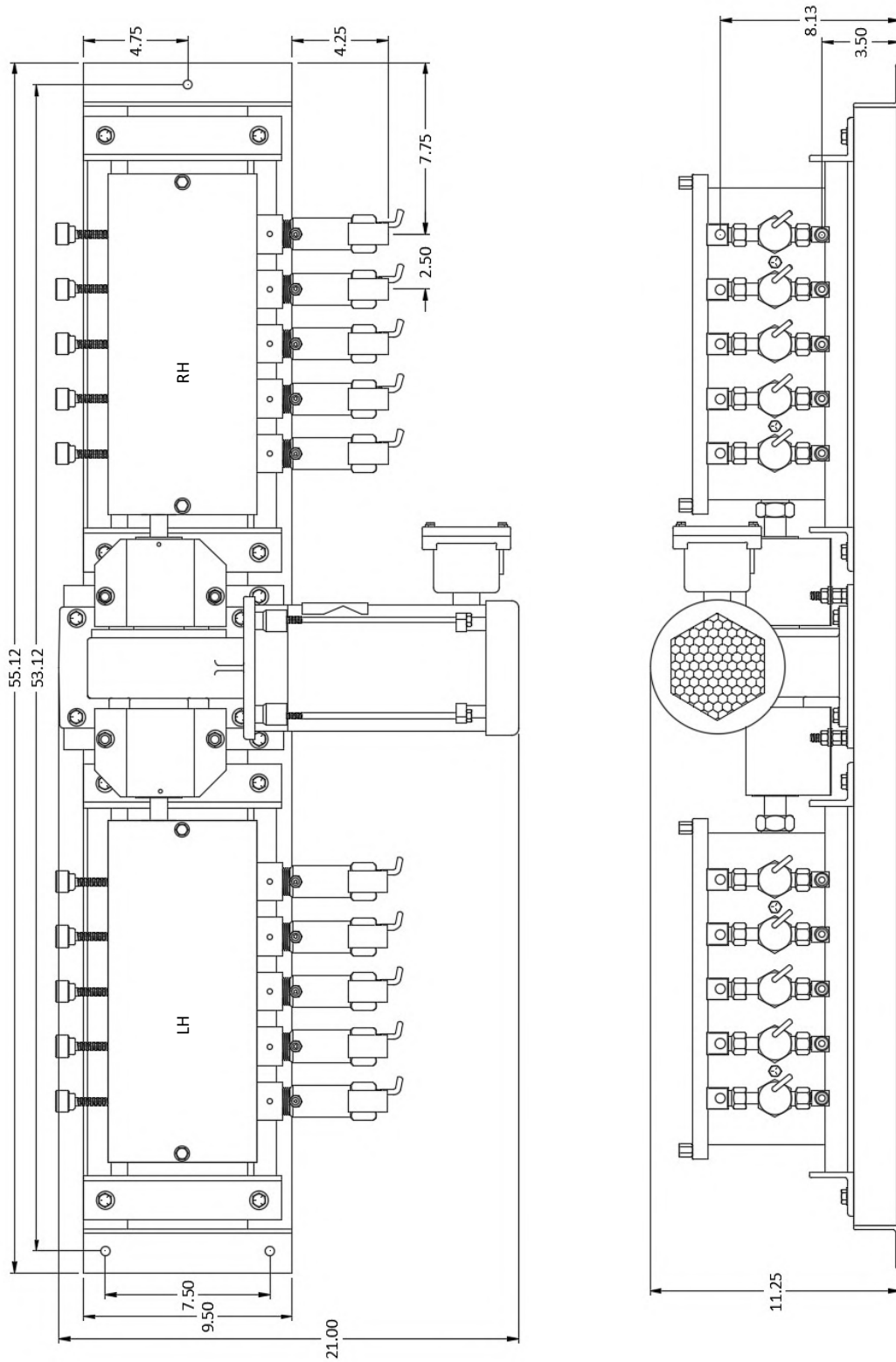

Western Chemical Pumps, Inc.
 603 South Kansas Avenue, Olathe, KS 66061
 913 - 829 - 1888 | sales@westernchemicalpumps.com

Dimensions are in inches. Actual product may have variance in measurements.
 All images are for illustrative purposes. Actual product may differ.

Western Chemical Pumps, Inc. reserves the right to make changes in specifications and features shown herein, or discontinue the product described at any time without notice or obligation. Contact your Western Chemical Pumps, Inc. distributor for the most current information.